

# feather&black

## Carraway Bed - Assembly Instructions

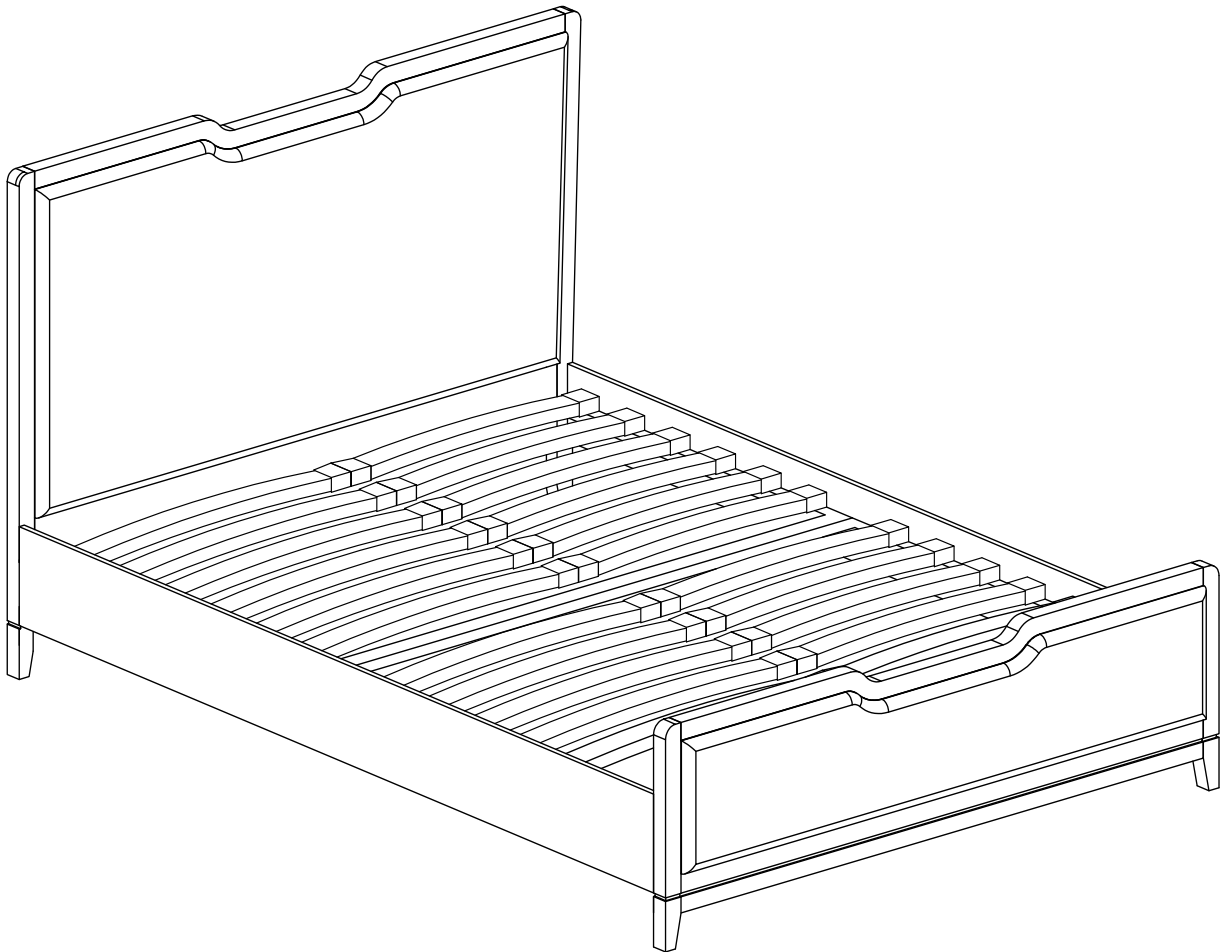

Sprung Slats

If you require any advice during assembly, please call our customer service team on 01243 380600

**Please retain these assembly instructions for future use**

# feather&black

## Carraway Bed

### Before you start

Thank you for purchasing this Carraway platinum bed.

Please read these instructions fully prior to assembly to familiarise yourself with the various stages of construction. Carefully open all packs supplied and check the contents against the parts and fittings check list.

Do not destroy any of the packaging until you are certain that you have all the necessary parts for the assembly.

This item is heavy once assembled. Please try to assemble the item as close as possible to the point of use. Take care when moving the item to avoid personal injury or damage to the product and always lift rather than drag.

There are small components used in the construction of this furniture as well as plastic packaging, these should be kept away from young children whilst assembling.

#### Product Safety

All assembly fastenings should always be tightened properly, and care should be taken to ensure that no fittings are loose.

Periodically check and ensure that all components are in their proper position, free from damage, and that all connectors are tight.

Please note depending on the lighting, positioning and surroundings of your room, the shade of the colour can sometimes appear slightly different. Over a period of time the colour might lighten or fade slightly due to light exposure.

#### Product Care

To clean, slightly moisten cloth with water and wipe surfaces. A damp cloth holds dust and prevents damage. repeat with a dry, soft, lint-free cloth. Do not use abrasives or cleaning products which may contain ammonia or solvents.

#### Number of people required to assemble

Two people to assemble the product and two people to lift in to position.



#### Time to assemble



20 minutes

#### Necessary tools



Tape measure

#### Missing parts or faulty products

If you are missing any fixtures or fittings during assembly, or a part is unfortunately faulty please call our customer service team on 01243 380600

# feather&black

## Carraway Bed

### Components supplied (not actual size)

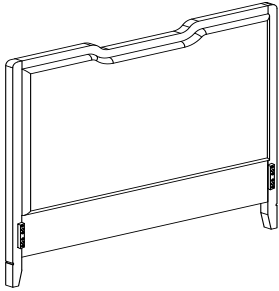

**A: Headboard**  
Quantity: 1

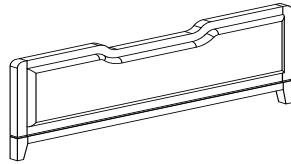

**B: Footboard**  
Quantity: 1

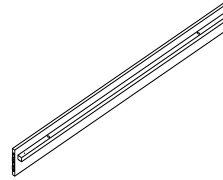

**C: Left side rail**  
Quantity: 1

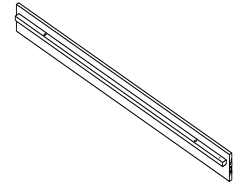

**D: Right side rail**  
Quantity: 1

### Fixtures and fittings supplied (not actual size)



**F: Bolt**  
M6x12 (mm)  
Quantity: 8 pcs

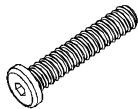

**G: Bolt**  
M6x45 (mm)  
Quantity: 4 pcs



**K: Flat Washer**  
M6 (mm)  
Quantity: 4 pcs

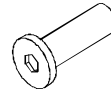

**L: Sleeve Nut**  
M6x20 (mm)  
Quantity: 4 pcs



**N: Allen Key**  
M4x110 (mm)  
Quantity: 2 pcs



**M: Springwasher**  
M6 (mm)  
Quantity: 4 pcs

Note: The following fitting will be found in the box which contains the Sprung Frame, NOT with the bedframes Assembly Kit

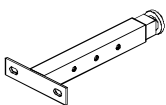

**O: Center leg**  
Quantity: 2 pcs

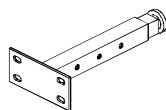

**P: Center leg**  
Quantity: 1 pc



**Q: Bolt**  
M6x20 (mm)  
Quantity: 8 pcs



**R: Washer**  
M6 (mm)  
Quantity: 8 pcs

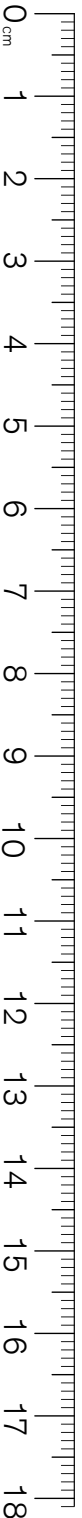

# feather&black

## Carraway Bed

Use Bolts (F) to fix the Side Rails (C) and (D) onto Headboard (A) and Footboard (B) by using Allen Key (N).

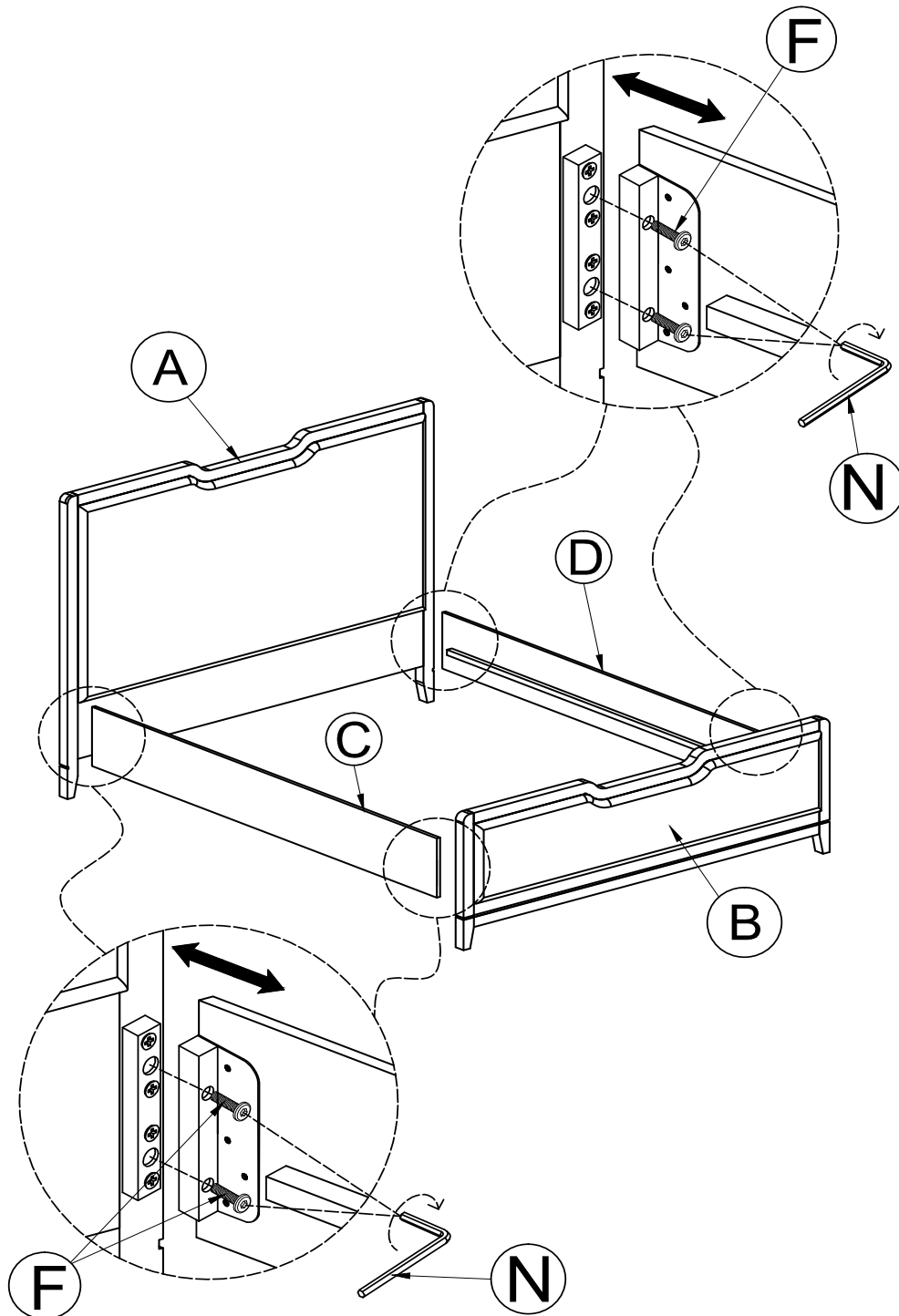

# feather&black

## Carraway Bed

*Sprung slat system*

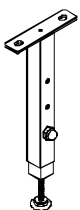
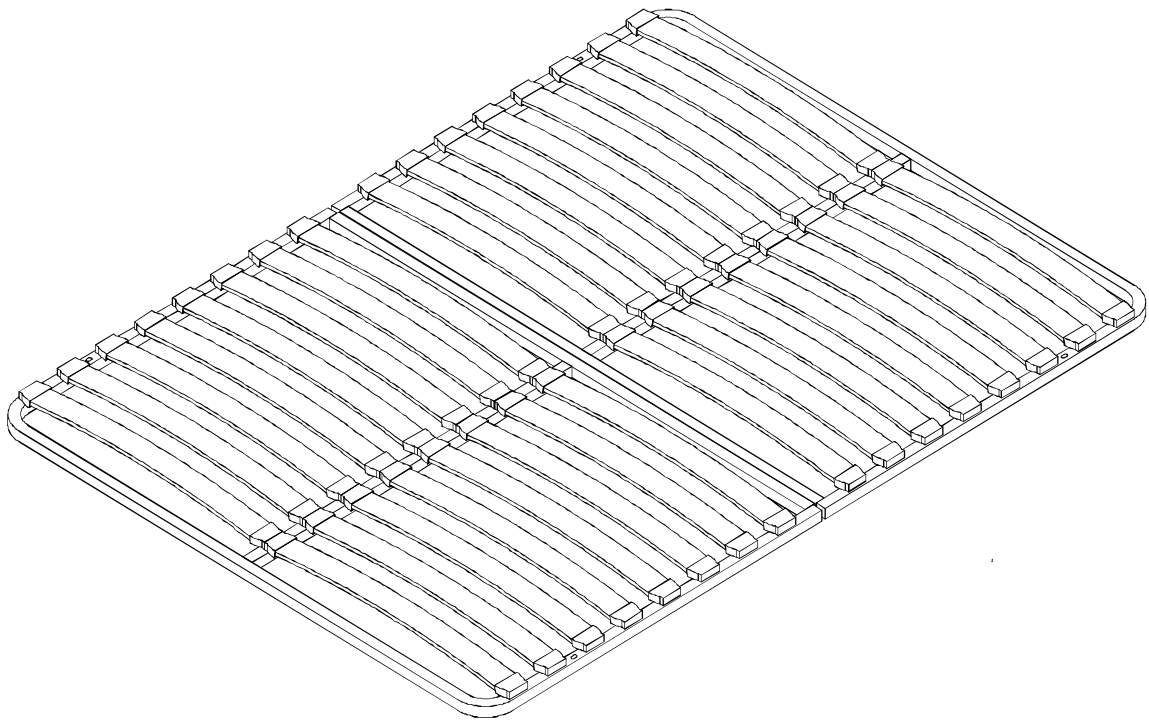

O: Center Leg

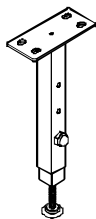

P: Center leg

# feather&black

## Carraway Bed

*Secure the center legs (O) & (P) onto the frame using bolts (Q), washer (R), and allen key (N).*

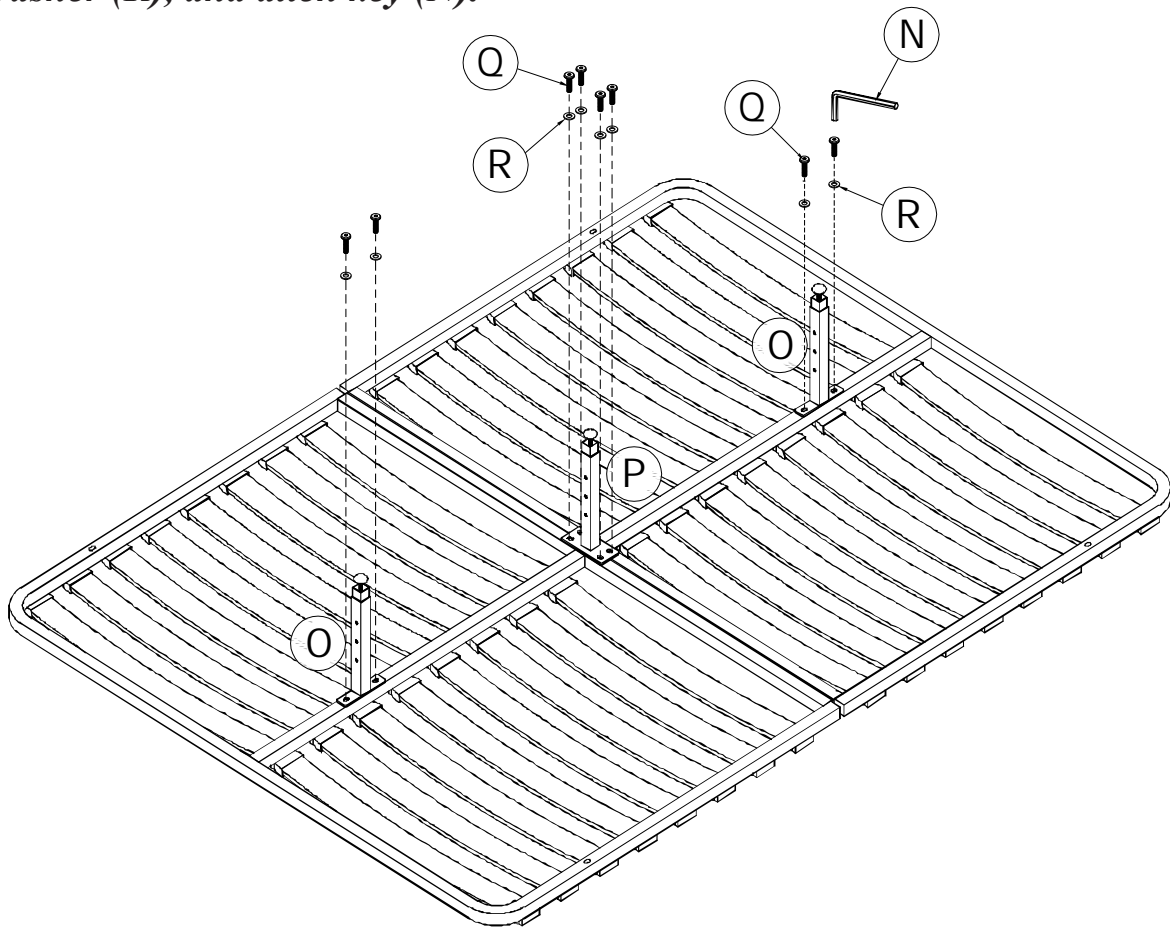

*Adjust leg height to suit bed frame*

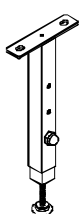
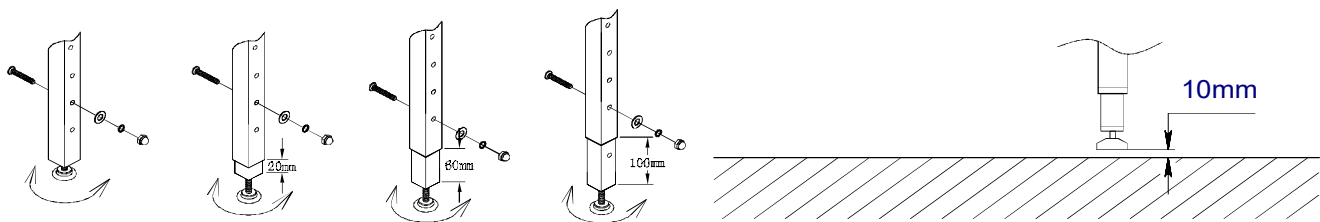

O: Center Leg

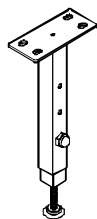

P: Center leg



Q: Bolt M6x20mm

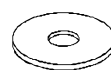

R: Flat washer



N: Allen Key

# feather&black

## Carraway Bed

- Turn the metal slat frame upward and carefully lower it into the bed. Ensure the frame rests on the side rail, align the holes in the slat frame with those in the side rail.
- Secure the slat frame to the side rail by threading bolts (G) & flat washer (K) through the corresponding holes into the sleeve nuts (L). Finally, tighten the bolts (G) using allen key (N).

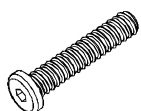
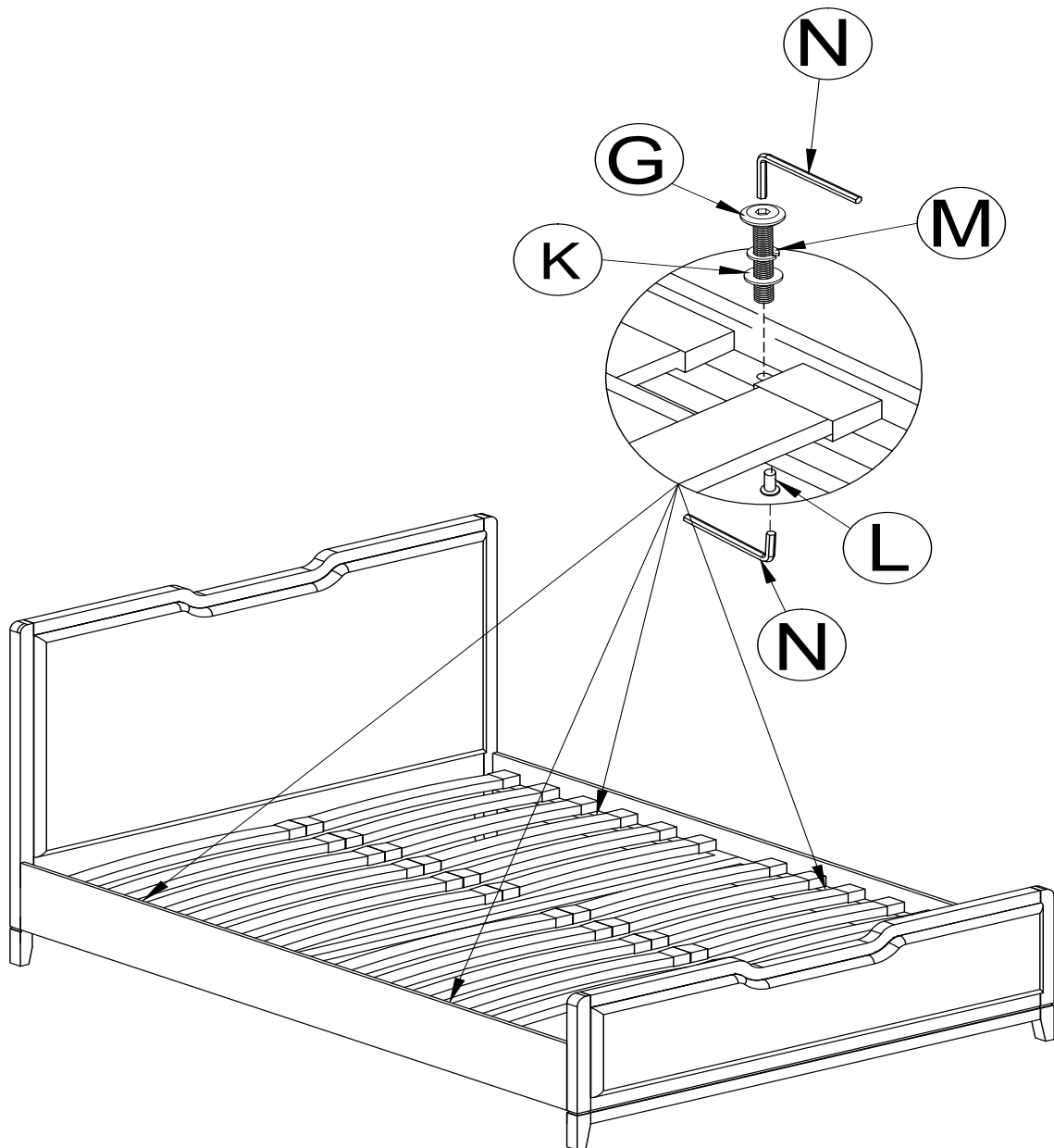

**G: Bolt M6x45mm**



**K: Flat washer**

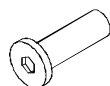

**L: Sleeve nut**



**N: Allen Key**



**M: Spring washer**