

feather&black

Camber Bedside Table Assembly Guide



Welcome to the Feather & Black community.

Since 2004, we've been passionately helping our customers create beautiful bedrooms with an exceptional level of quality and expertise.

We know your home is a truly special place, so it's a responsibility we don't take lightly. That's why all of our furniture is handcrafted using only the finest materials. Considering every fine detail, every twist, turn and corner, we create pieces that truly reflect your style.

We hope you love this stunning new addition to your home. If we can be of any assistance, please don't hesitate to get in touch with us. You can call 01243 380600 (option 2), email customerservices@featherandblack.com or chat with a member of our team live at [featherandblack.com](https://www.featherandblack.com).

We simply adore seeing our furniture come to life in its forever home, so don't forget to share your style with the world. We'd love for you to tag us on Instagram @featherandblack and include #featherandblack so we can bask in its beauty too!

From our home to yours, thank you for choosing thoughtfully crafted furniture that's made to be cherished.

Sincerley,

The Feather & Black Team

Camber Bedside Table - Assembly Instructions

Product size: 600mm x 400mm x 600mm

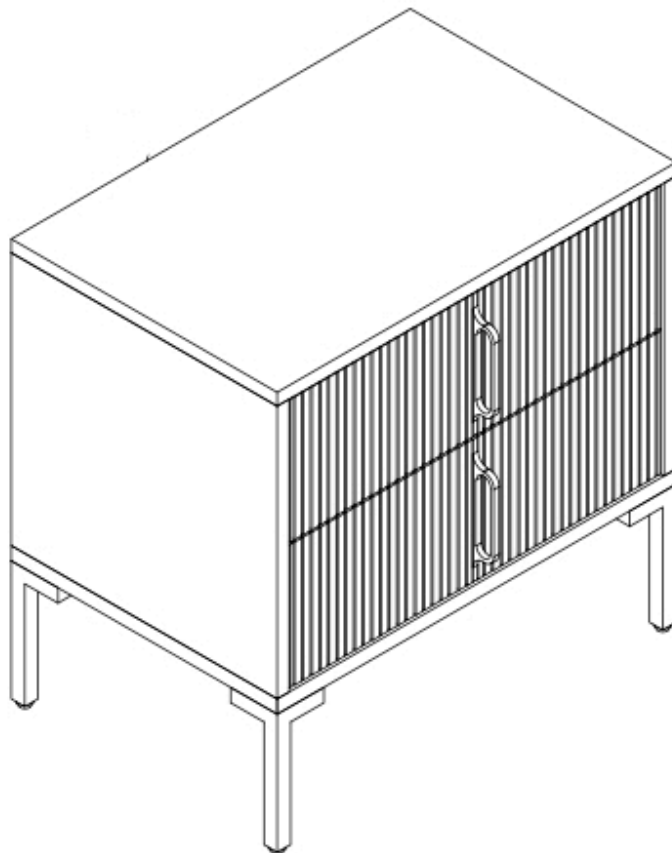

If you require any advice during assembly, please call our customer service team on 01243 380600

Please retain these assembly instructions for future use

Camber Bedside Table

Before you start

Thank you for purchasing this Camber Bedside Table.

Please read these instructions fully prior to assembly to familiarise yourself with the various stages of construction. Carefully open all packs supplied and check the contents against the Parts and fittings check list.

Do not destroy any of the packaging until you are certain that you have all the necessary parts for the assembly.

This item is heavy once assembled. Please try to assemble the item as close as possible to the point of use. Take care when moving the item to avoid personal injury or damage to the product and always lift rather than drag.

There are small components used in the construction of this furniture as well as plastic packaging, these should be kept away from young children whilst assembling.

Product Safety

All assembly fastenings should always be tightened properly, and care should be taken to ensure that no fittings are loose

Periodically check and ensure that all components are in their proper position, free from damage, and that all connectors are tight.

Please note depending on the lighting, positioning and surroundings of your room, the shade of the colour can sometimes appear slightly different. Over a period of time the colour might lighten or fade slightly due to light exposure.

Product Care

To clean, slightly moisten cloth with water and wipe surfaces. A damp cloth holds dust and prevents damage. Repeat with a dry, soft, lint-free cloth. Do not use abrasives or cleaning products which may contain ammonia or solvents.

Number of people required to assemble

One person to assemble the product and one person to lift in to position.



Time to assemble



10 minutes

Necessary tools

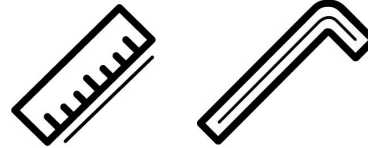

Missing parts or faulty products

If you are missing any fixtures or fittings during assembly, or a part is unfortunately faulty please call our customer service team on 01243 380600.

Camber Bedside Table

Components supplied (not actual size)

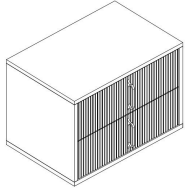

A: Main Unit
Quantity: 1 pc

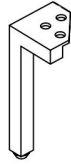

B: Metal Leg
Quantity: 4 pcs

Fixture and fittings supplied (not actual size)

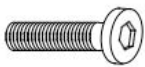

C: Bolt
M6 x 20mm
Quantity: 12 pcs



D: Metal Washer
Ø8/Ø18mm
Quantity: 12 pcs



E: Spring Washer
Ø8/Ø14mm
Quantity: 12 pcs



F: Allen Key
Quantity: 1 pc

Camber Bedside Table

1. Lay the Main Unit (A) on its back.

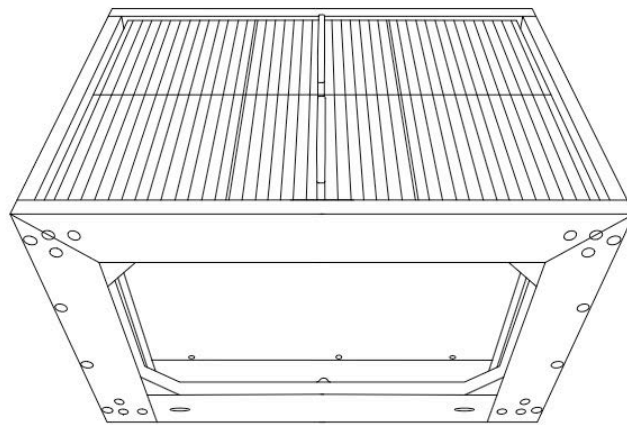

2. Attach each Metal Leg (B) using the Allen Key (F).

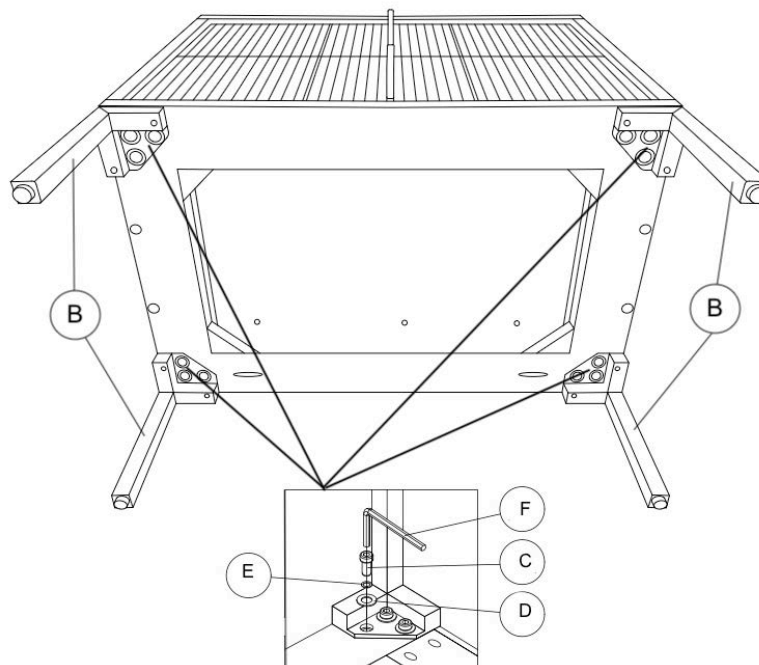

feather&black

Camber Bedside Table

3. Lift the assembled unit onto its feet.

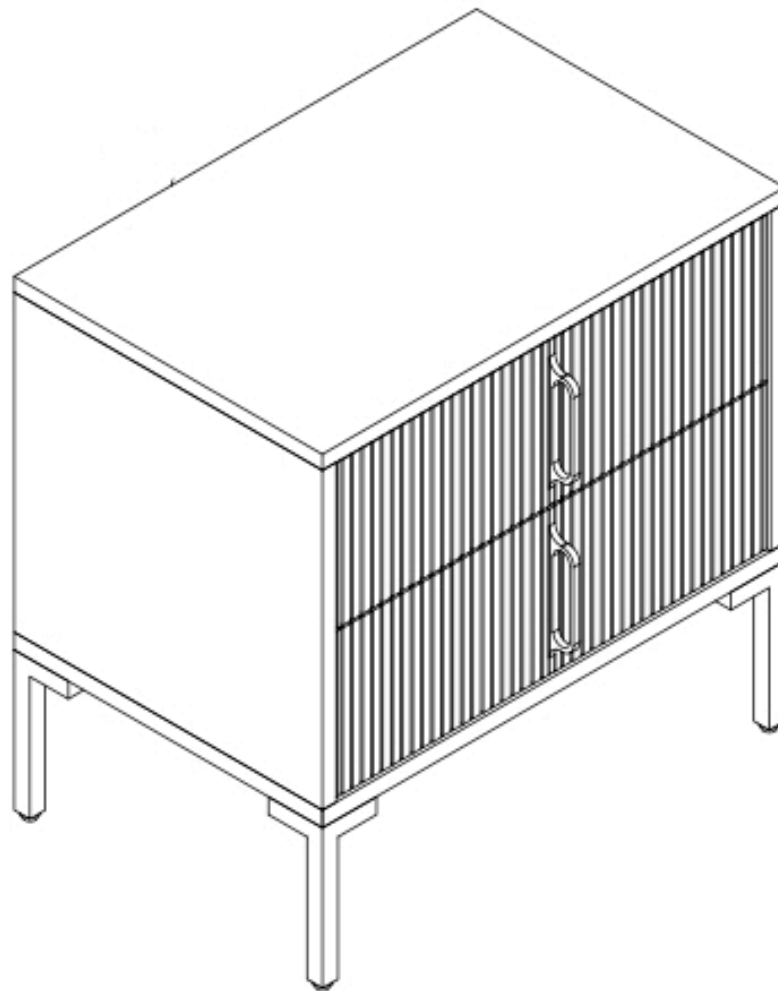

feather&black

featherandblack.com