

# feather&black

## Oliver Bed Assembly Guide



# Welcome to the Feather & Black community.

Since 2004, we've been passionately helping our customers create beautiful bedrooms with an exceptional level of quality and expertise. We know your home is a truly special place, so it's a responsibility we don't take lightly. That's why all of our furniture is handcrafted using only the finest materials. Considering every fine detail, every twist, turn and corner, we create pieces that truly reflect your style.

We hope you love this stunning new addition to your home. If we can be of any assistance, please don't hesitate to get in touch with us. You can call 01243 380600 (option 2), email [customerservices@featherandblack.com](mailto:customerservices@featherandblack.com) or chat with a member of our team live at [featherandblack.com](https://www.featherandblack.com).

We simply adore seeing our furniture come to life in its forever home, so don't forget to share your style with the world. We'd love for you to tag us on Instagram @featherandblack and include #featherandblack so we can bask in its beauty too!

From our home to yours, thank you for choosing thoughtfully crafted furniture that's made to be cherished.

Sincerley,

**The Feather & Black Team**

# feather&black

## Oliver Bed - Assembly Instructions

SMALL DOUBLE: 1290mm H x 1270mm W x 2005mm L

DOUBLE: 1290mm H x 1420mm W x 2005mm L

KING: 1290mm H x 1570mm W x 2120mm L

SUPER KING: 1290mm H x 1870mm W x 2120mm L

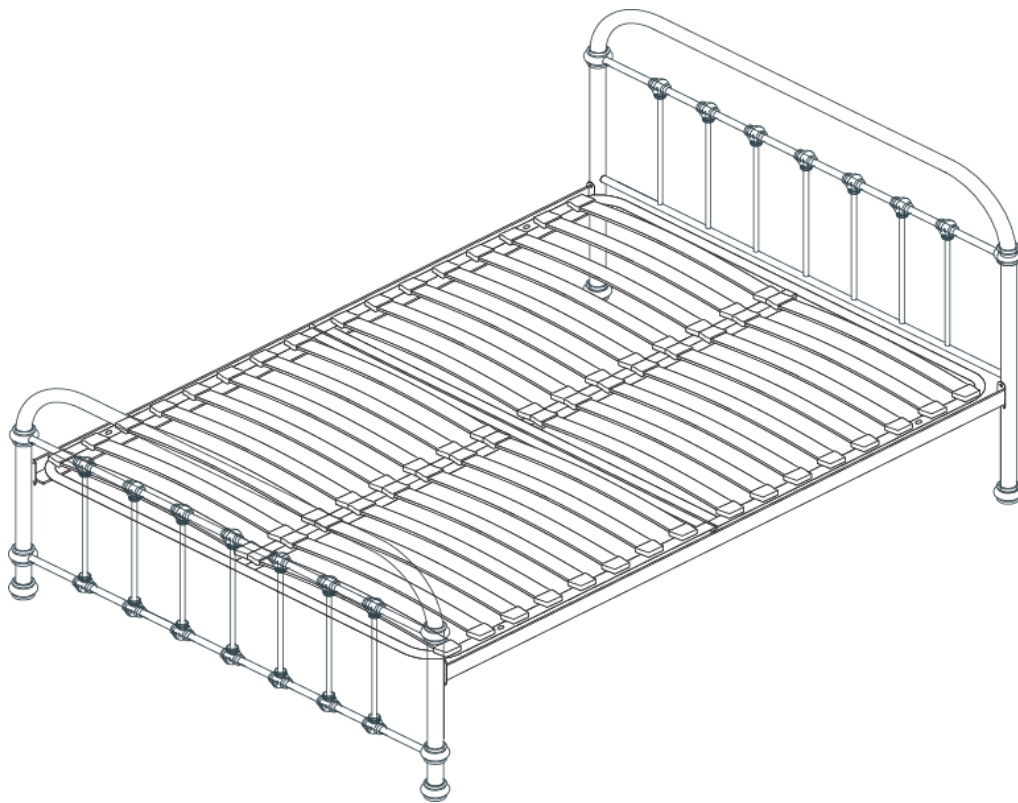

If you require any advice during assembly, please call our customer service team on 01243 380600

**Please retain these assembly instructions for future use**

# feather&black

## Oliver Bed

### Before you start

Thank you for purchasing this Oliver bed.

Please read these instructions fully prior to assembly to familiarise yourself with the various stages of construction. Carefully open all packs supplied and check the content against the parts and fitting check list.

Do not destroy any of the packaging until you are certain that you have all the necessary parts for the assembly.

This item is heavy once assembled. Please try to assemble the item as close as possible to the point of use. Take care when moving the item to avoid personal injury or damage to the product and always lift rather than drag.

There are small components used in the construction of this furniture as well as plastic packaging, these should be kept away from young children whilst assembling.

#### Product Safety

All assembly fastenings should always be tightened properly, and care should be taken to ensure that no fittings are loose.

Periodically check and ensure that all components are in their proper position, free from damage, and that all connectors are tight

Please note depending on the lighting, positioning and surroundings of your room, the shade of the colour can sometimes appear slightly different. Over a period of time the colour might lighten or fade slightly due to light exposure.

#### Product Care

To clean, slightly moisten cloth with water and wipe surfaces. A damp cloth holds dust and prevents damage. repeat with a dry, soft, lint-free cloth. Do not use abrasives or cleaning products which may contain ammonia or solvents.

#### Number of people required to assemble

Two people to assemble the product and two people to lift in to position.



#### Time to assemble



20 minutes

#### Necessary tools



#### Missing parts or faulty products

If you are missing any fixtures or fittings during assembly, or a part is unfortunately faulty please call our customer service team on 01243380600

# feather&black

## Oliver bed

### Components supplied (not actual size)



A: Headboard  
Quantity: 1pc  
Box Number: 1

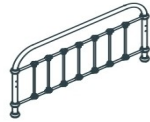

B: Footboard  
Quantity: 1pc  
Box Number: 1



C: Left Side Rail  
Quantity: 1pc  
Box Number: 2



D: Right Side Rail  
Quantity: 1pc  
Box Number: 2

### Fixtures and fittings supplied (not actual size)

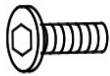

E: Bolt  
M6 x 20mm  
Qty: 12 pcs  
Box Number: 1



F: Plastic Washer  
M6  
Qty: 8 pcs  
Box Number: 1



G: Curved Metal  
Washer M6  
Qty: 8 pcs  
Box Number: 1



H: Metal Sprung  
Washer M6  
Qty: 8 pcs  
Box Number: 1

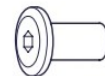

I: Sleeve Nut  
M6 x 20mm  
Qty: 4 pcs  
Box Number: 1



J: Metal Washer  
Diameter 22mm  
Qty: 8 pcs  
Box Number: 1



K: Allen Key  
Qty: 2 pcs  
Box Number: 1

**Note: the following fittings will be found in the box which contains the Sprung Frame, NOT with the bedframe Assembly Kit**



L: Outer  
Support leg  
Qty: 2 pcs



M: Centre  
Support leg  
Qty: 1pc



N: Bolt  
M6 x 20mm  
Qty: 8 pcs



O: Flat Washer  
M6  
Qty: 8 pcs

0 cm  
1  
2  
3  
4  
5  
6  
7  
8  
9  
10  
11  
12  
13  
14  
15  
16  
17  
18

# feather&black

## Oliver Bed

1. Use Bolts (E) and Washers (F, G, H) to fix the side Rails (C) and (D) onto Headboard (A) and Footboard (B). Tighten all bolts securely with the Allen Key (K).

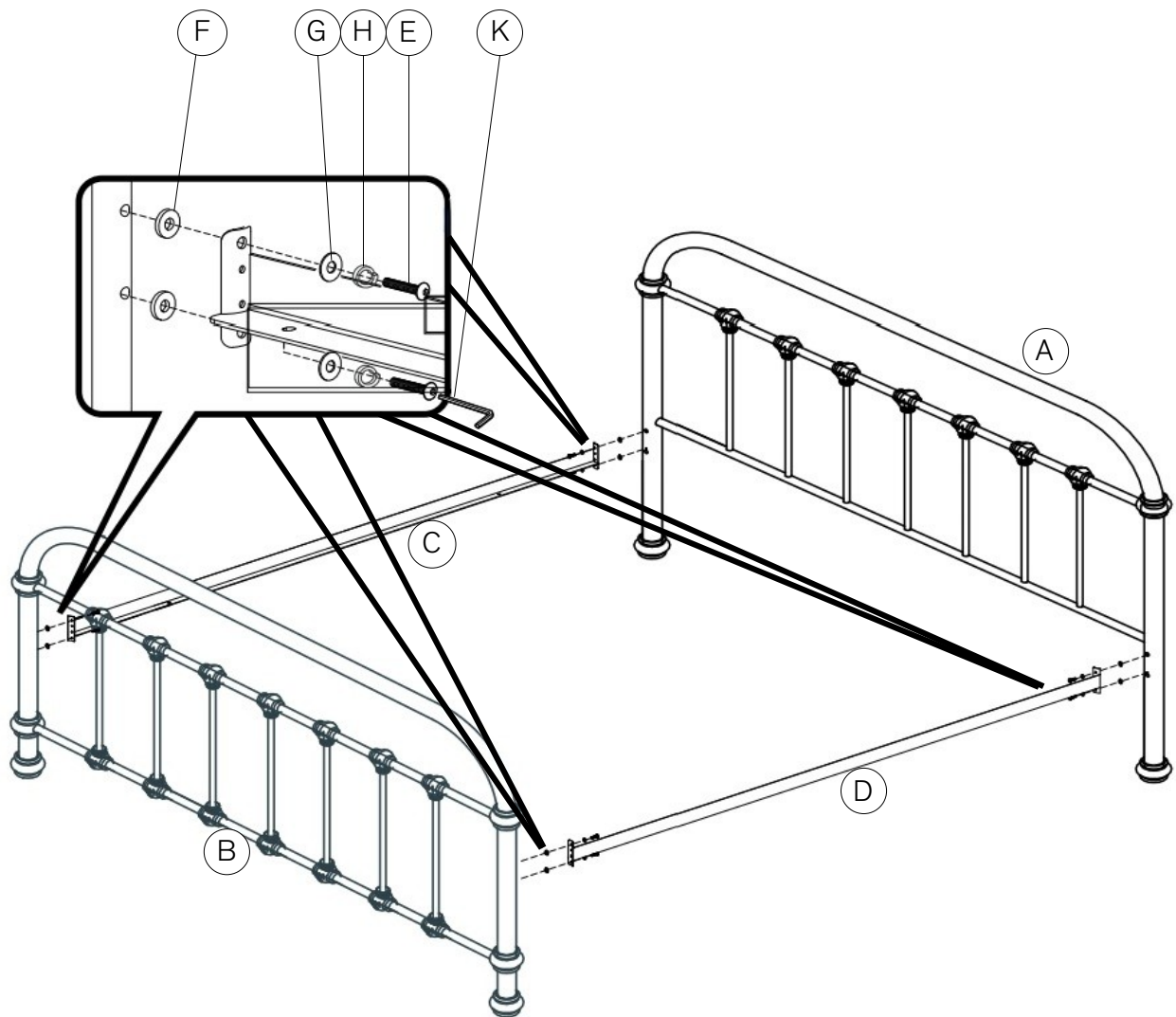

# feather&black

## Oliver Bed

### 2. Sprung Slat System

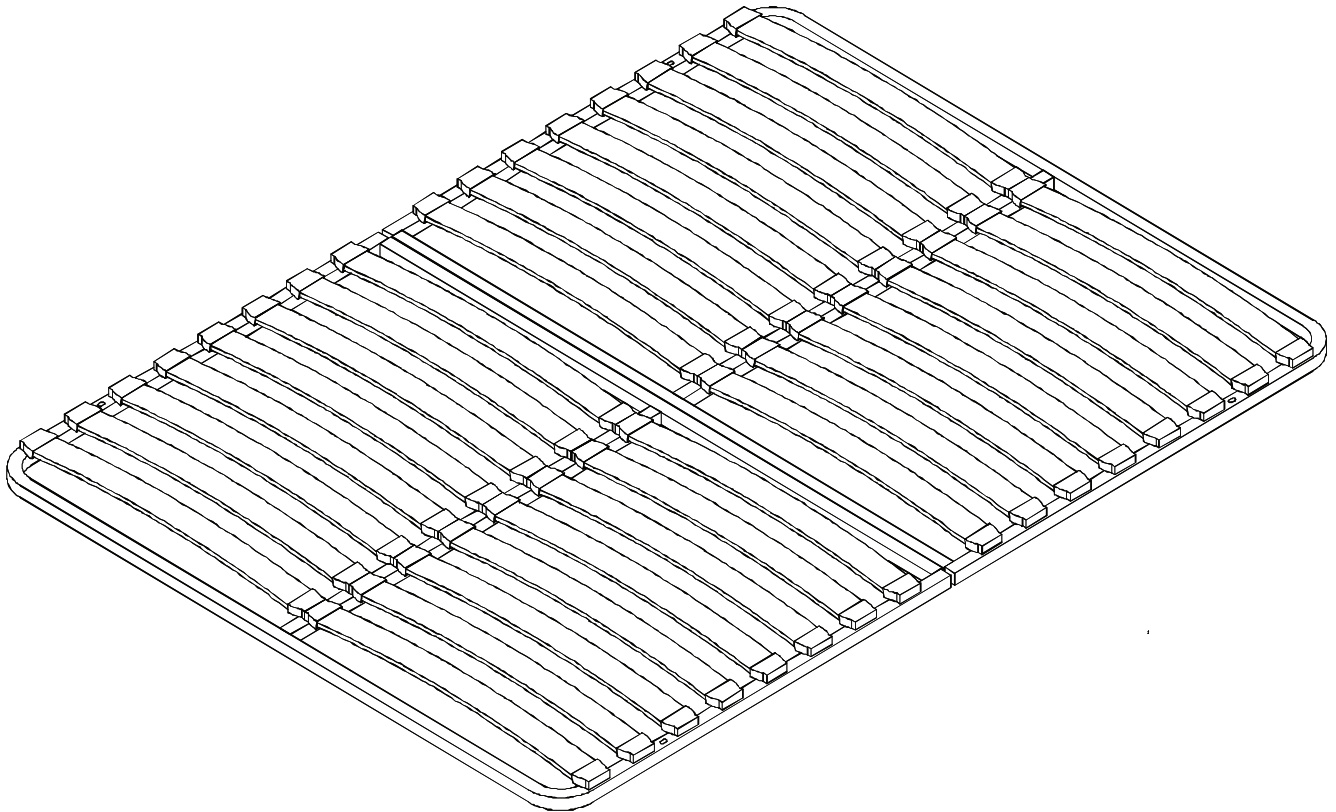

# feather&black

## Oliver Bed

3. Open the sprung slat frame and lay face down on the floor. Secure Support Legs (L) and (M) to frame using Bolts (N) and Washers (O). Tighten securely with Allen Key (K).

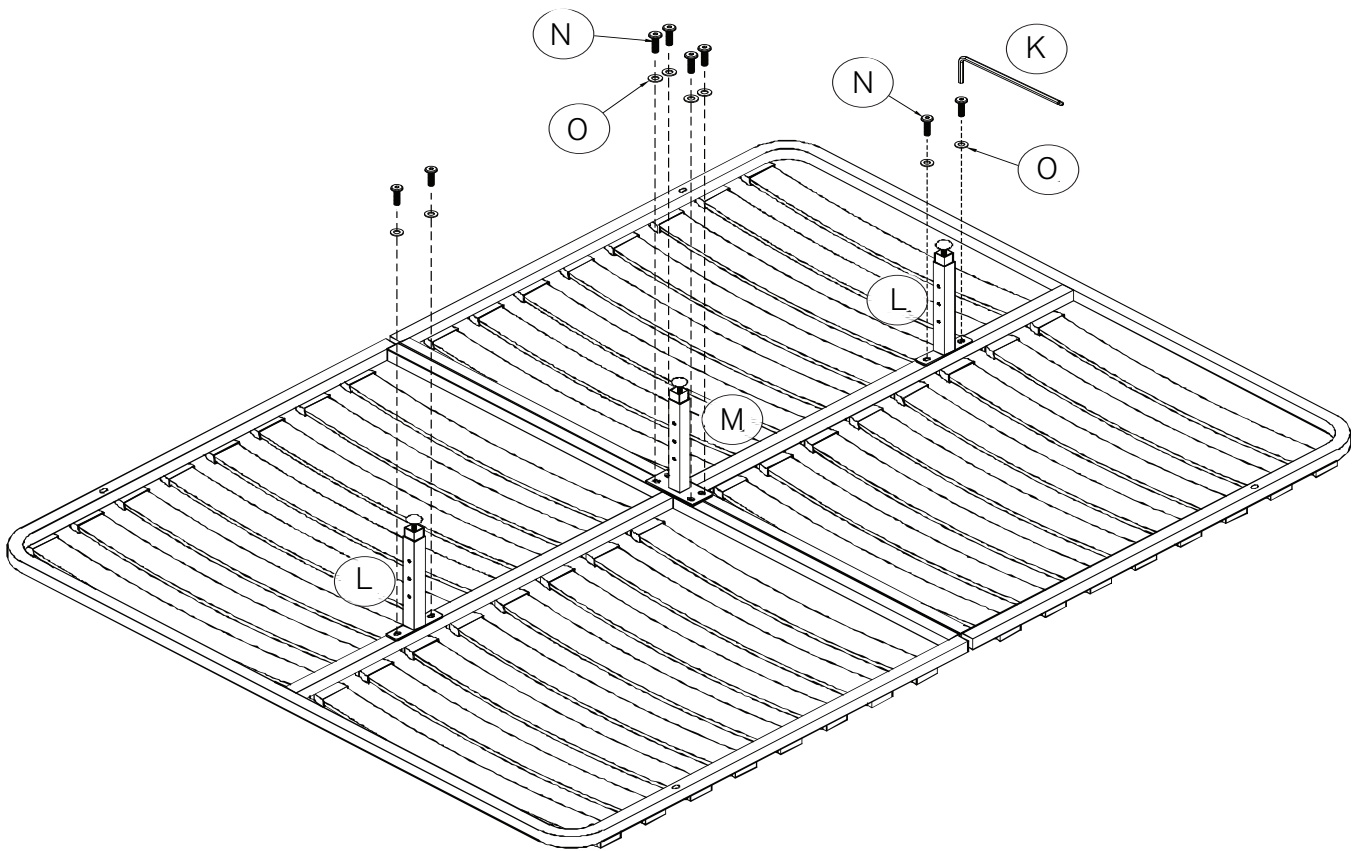

Adjust leg height to suit bed frame

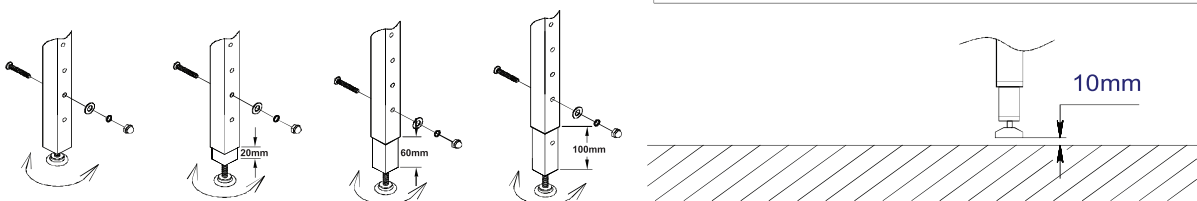



# feather&black

## Oliver Bed

4. Turn the metal slat frame upward and carefully lower into the bed frame. Ensure the slat frame rests on the side rails and align the hole in the slat frame with those in the side rails. Secure the slat frame to the side rails by threading Bolts (E) and Washers (J) through the corresponding holes into the Nuts (I). Tighten all bolts securely using both Allen Keys (K).

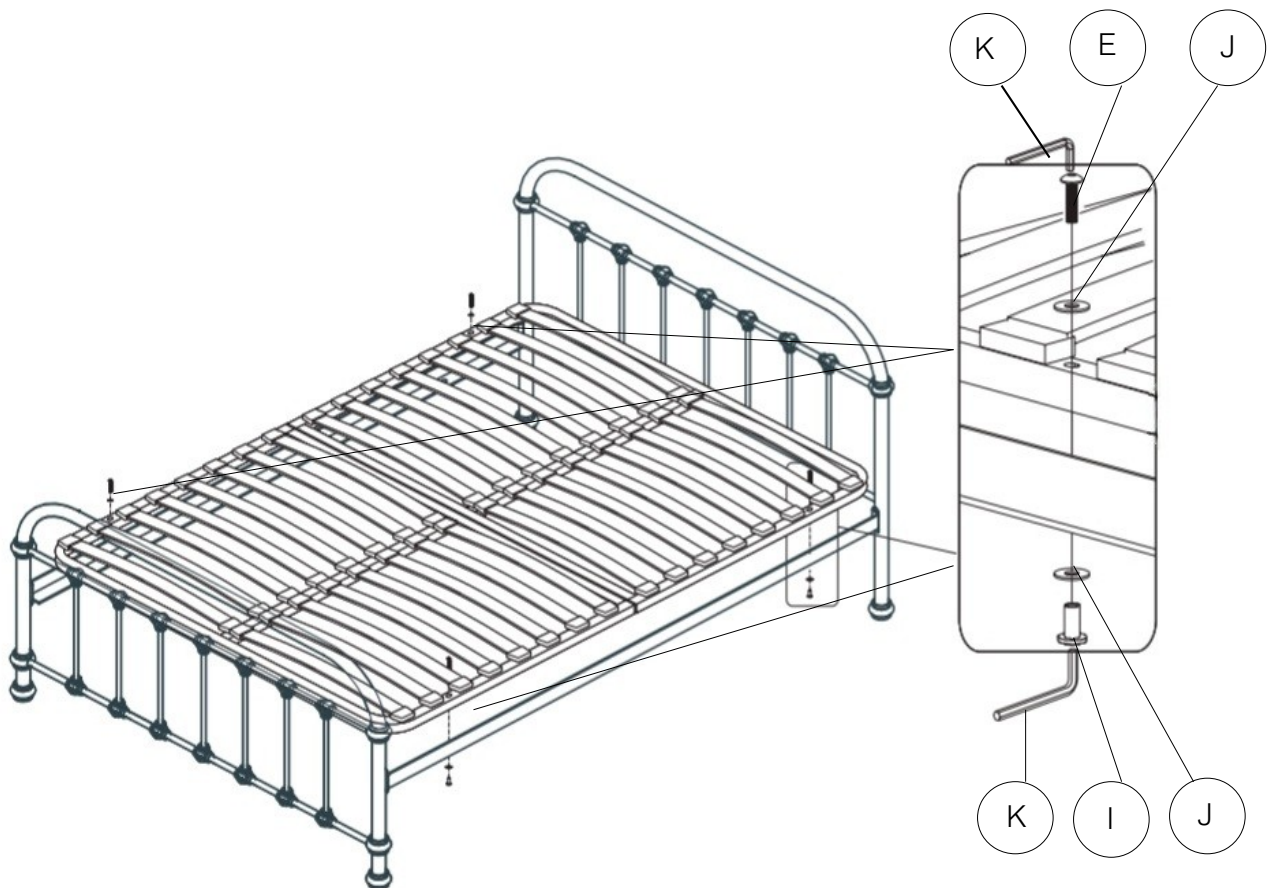

feather&black

[featherandblack.com](http://featherandblack.com)